

GAMME NEPTUNE

MODELE: COMPACT

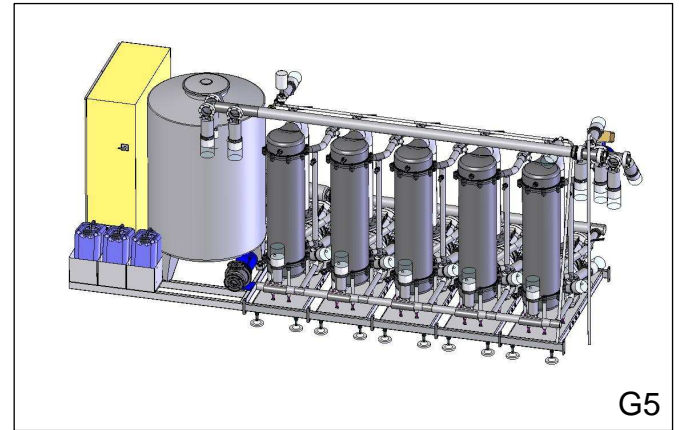
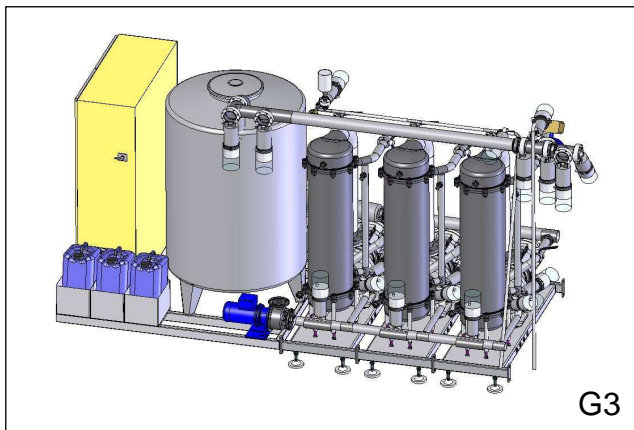
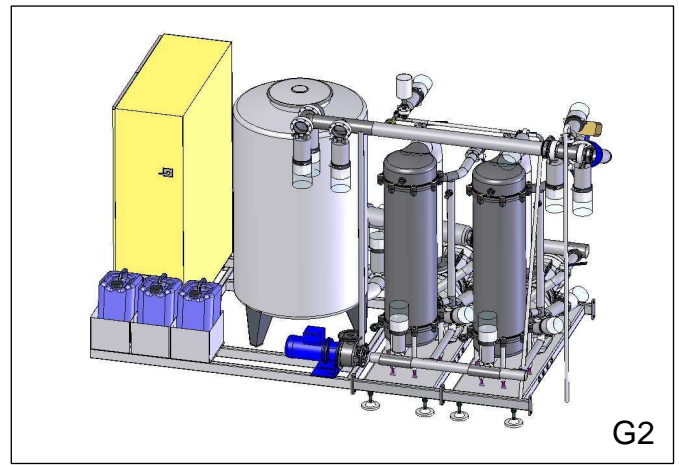
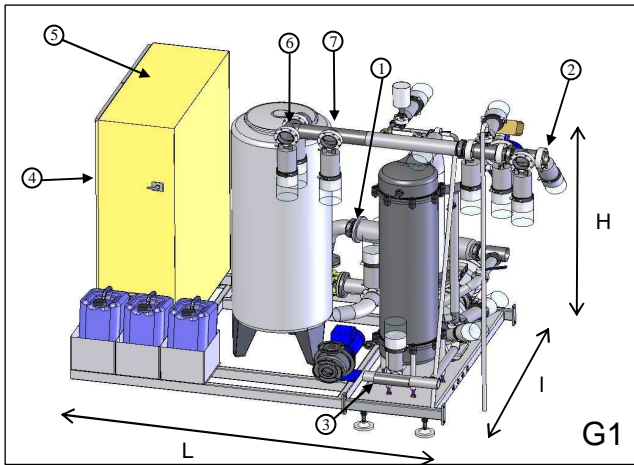

Caractéristiques techniques/ Technical description				Valeur / Value				
repère	Désignations	Description	Unité	G1	G2	G3	G4	G5
L	Longueur	Length	mm	2750	3500	4050	5300	5900
I	Largeur	Width	mm	1600	1600	1600	1600	1600
H	Hauteur	Height	mm	2550	2550	2550	2550	2550
	Débattement réglage pieds	Course adjustment feet	mm	80	80	80	80	80
	Pente maximale admissible	Acceptable maximum slope	%	3	2.3	2	1.5	1.3
	Masse à vide	Empty weight	Kg	1050	1500	1950	2400	2850
	Masse plein	Full weight	Kg	1700	2800	3900	5000	5600
	Tension d'alimentation	Supply voltage	V	400	400	400	400	400
	Fréquence	Frequency	Hz	50	50	50	50	50
	Puissance totale	Total power	KW	14.5	25	40	55	70
	Régime de neutre	Mode of neutral	TN	TN	TN	TN	TN	TN
1	Arrivée produit à filtrer	Products to be filtered inlet	sms	63	76	104	129	154
2	Sortie produit filtré	Products to be filtered outlet	sms	63	76	104	129	154
3	Sortie rejet	Reject outlet	sms	63	76	76	76	76
4	Raccordement pneumatique	Pneumatic connection	piquage	4/6	4/6	4/6	4/6	4/6
5	Raccordement électrique	Electric connection	cable	4G	4G	4G	4G	4G
6	Sortie rejet vers cuve neutralisation	Reject towards tank neutralization	sms	63	76	76	76	76
7	Arrivée d'eau de lavage	Washing water inlet	sms	63	76	76	76	76

REPRESENTATIONS ET CARACTERISTIQUES NON CONTRACTUELLES, DONNEES A TITRE INDICATIF ET SUSCEPTIBLES DE MODIFICATIONS SANS PREAVIS.